

# EA1000H6

Indoor & Outdoor  
500x1000mm Rental LED Display



## Feature:

1. Configure quick lock, support quick installation;
2. Corner protection design to protect the LED module;
3. Front and rear service design;
4. Hub Connection Design, with detachable Power box;
5. 500x1000mm size, lightweight design.

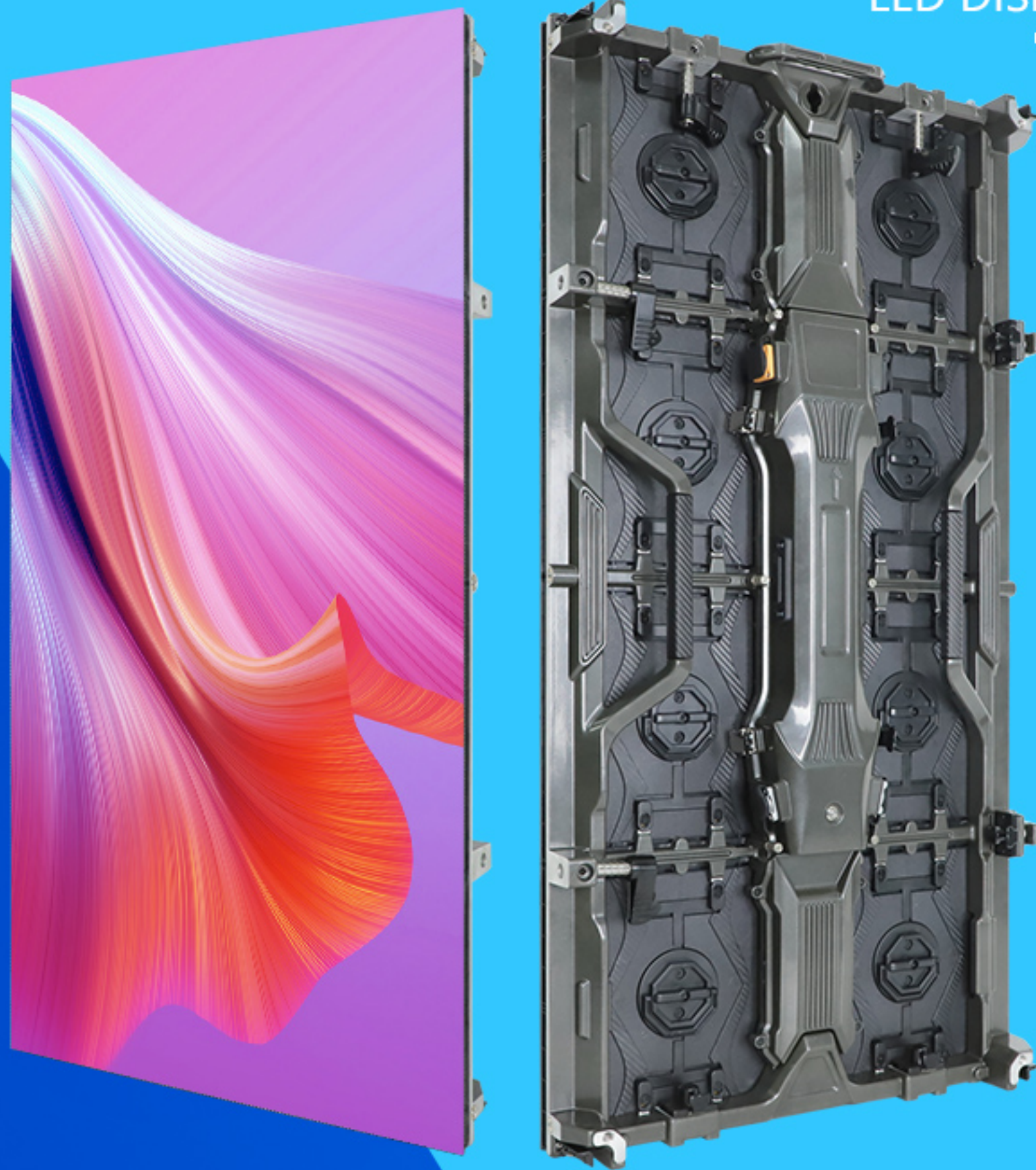



# Quick Install

One-man installation;  
fast lock design.

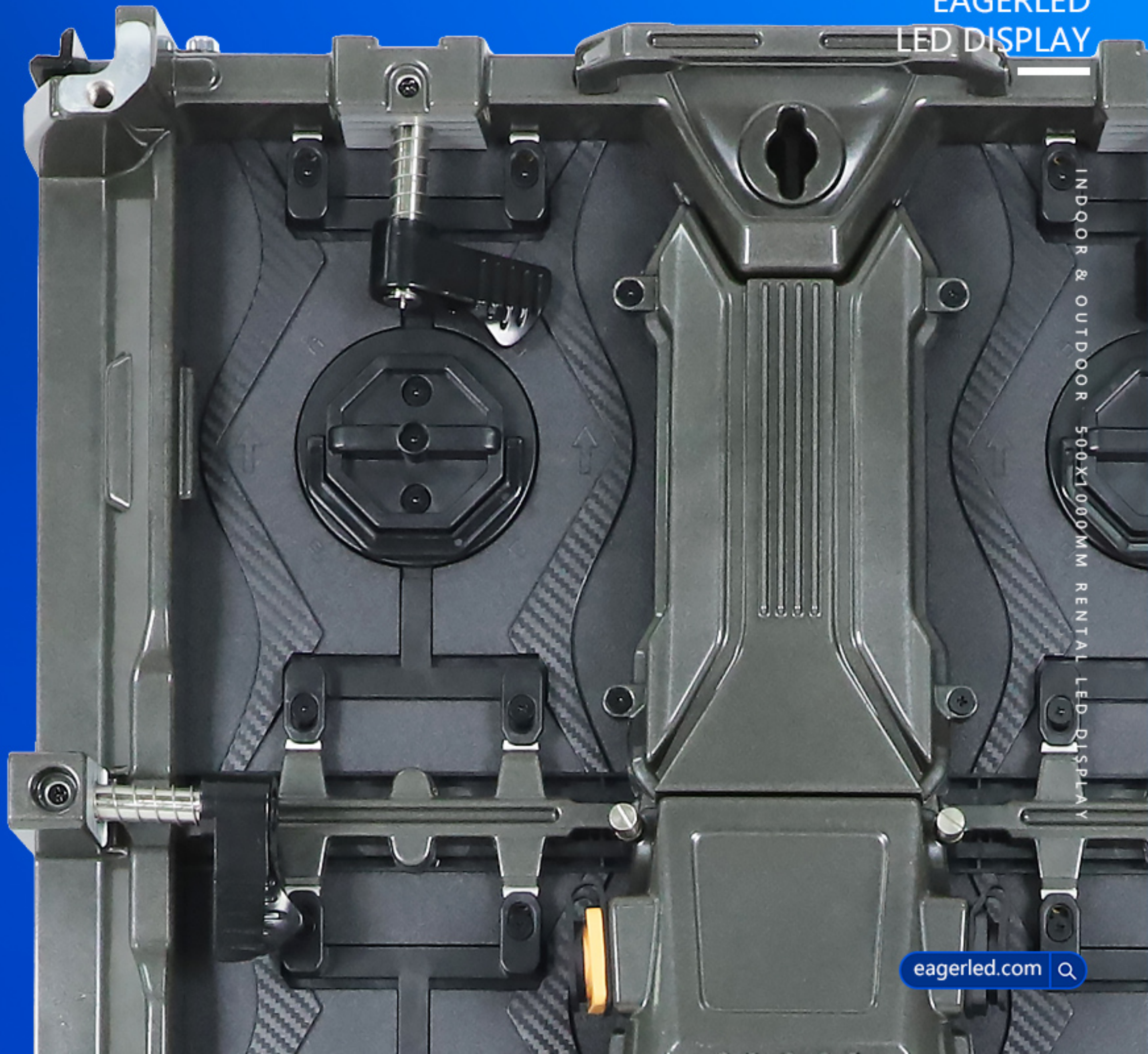



# Corner Protector

Anti-Collision on four corners,  
protect the LED lamp.





# Front & Rear Service

EA1000H6 series adopts front and rear designs to quickly replace LED modules..

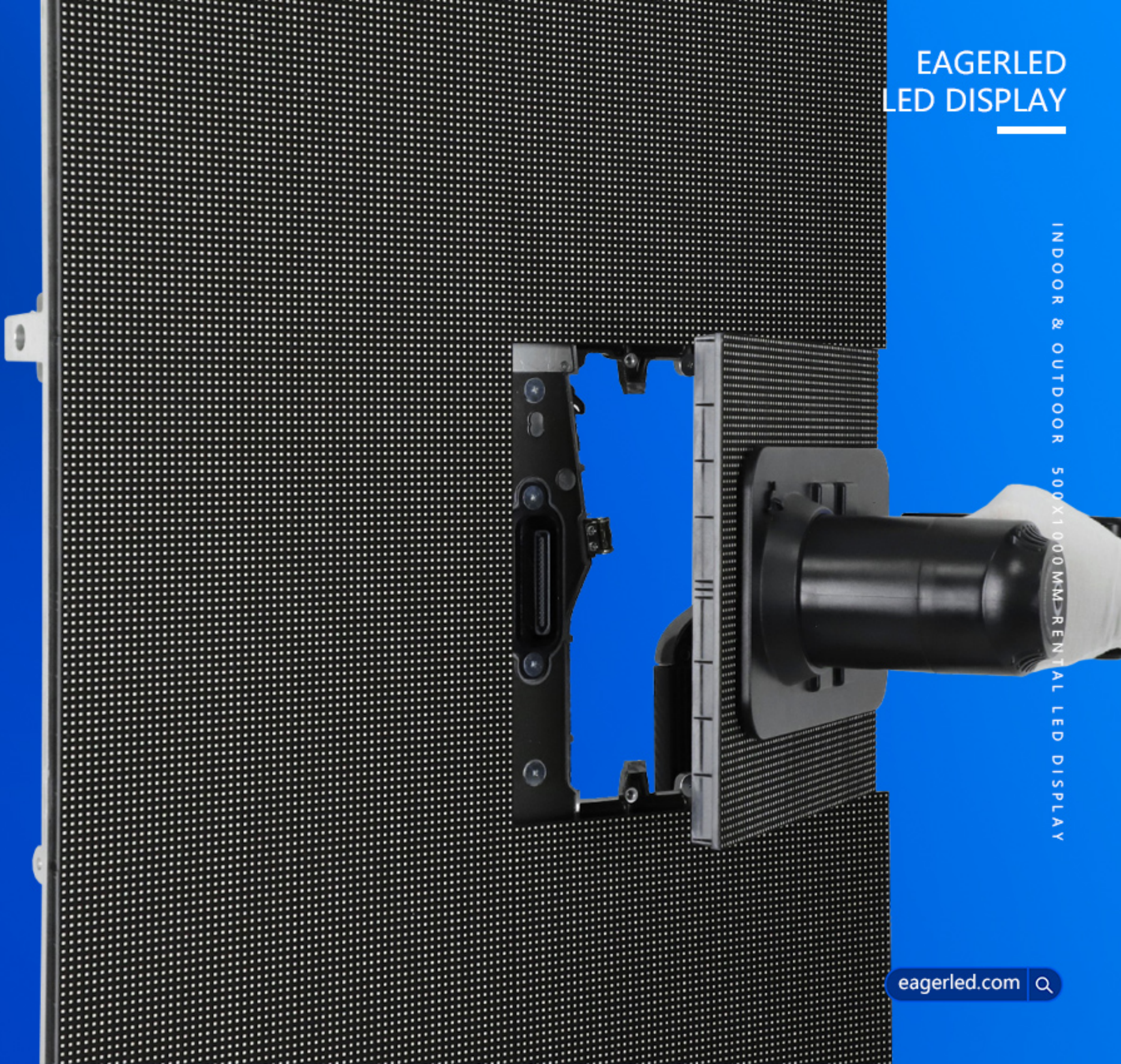



# Detachable Back Cover

The back cover of the power supply can be quickly opened for easy maintenance.





# Curved lock

Install curve locks for curved installation.(Optional)

INDOOR & OUTDOOR 500X1000MM RENTAL LED DISPLAY

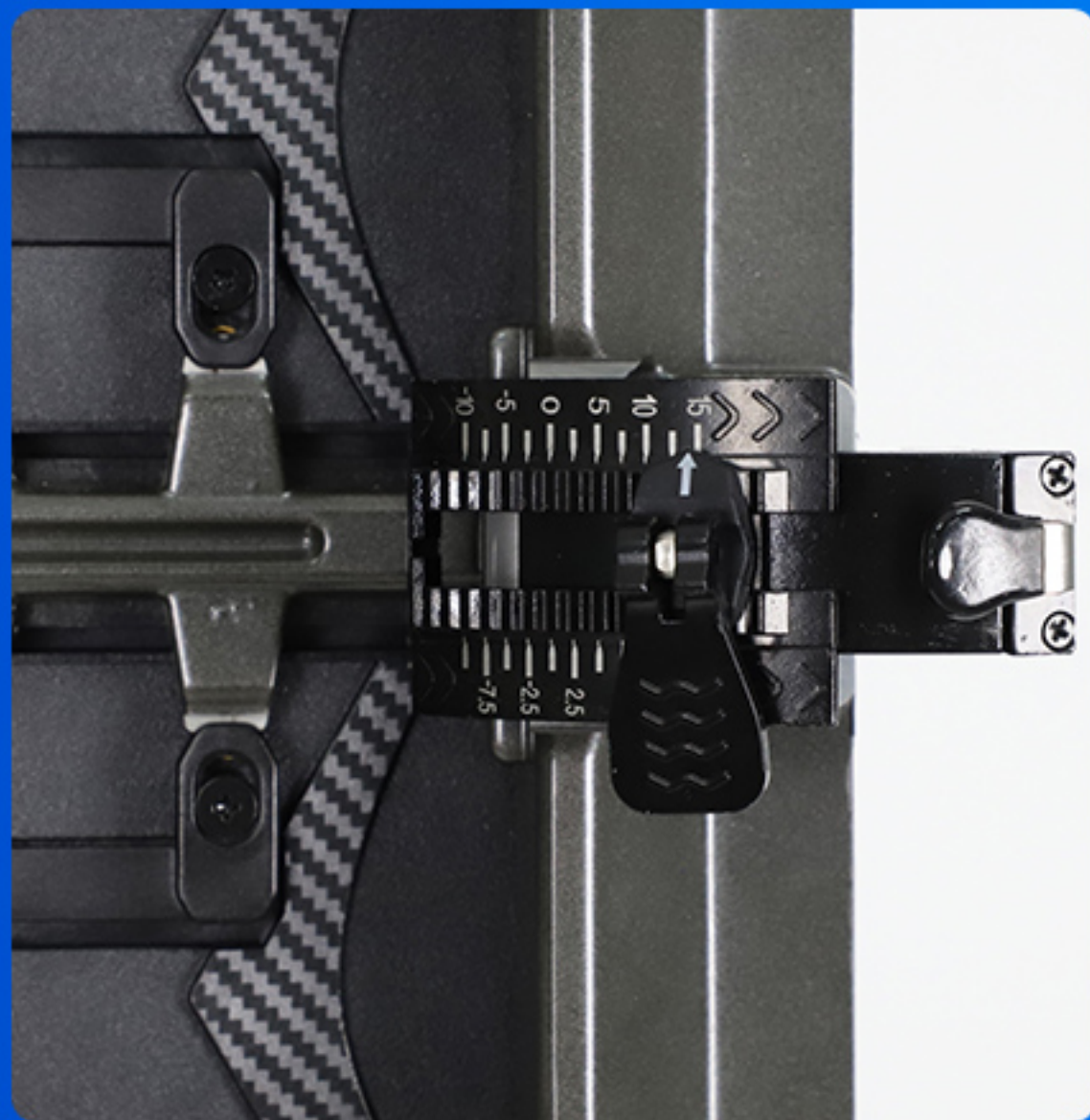
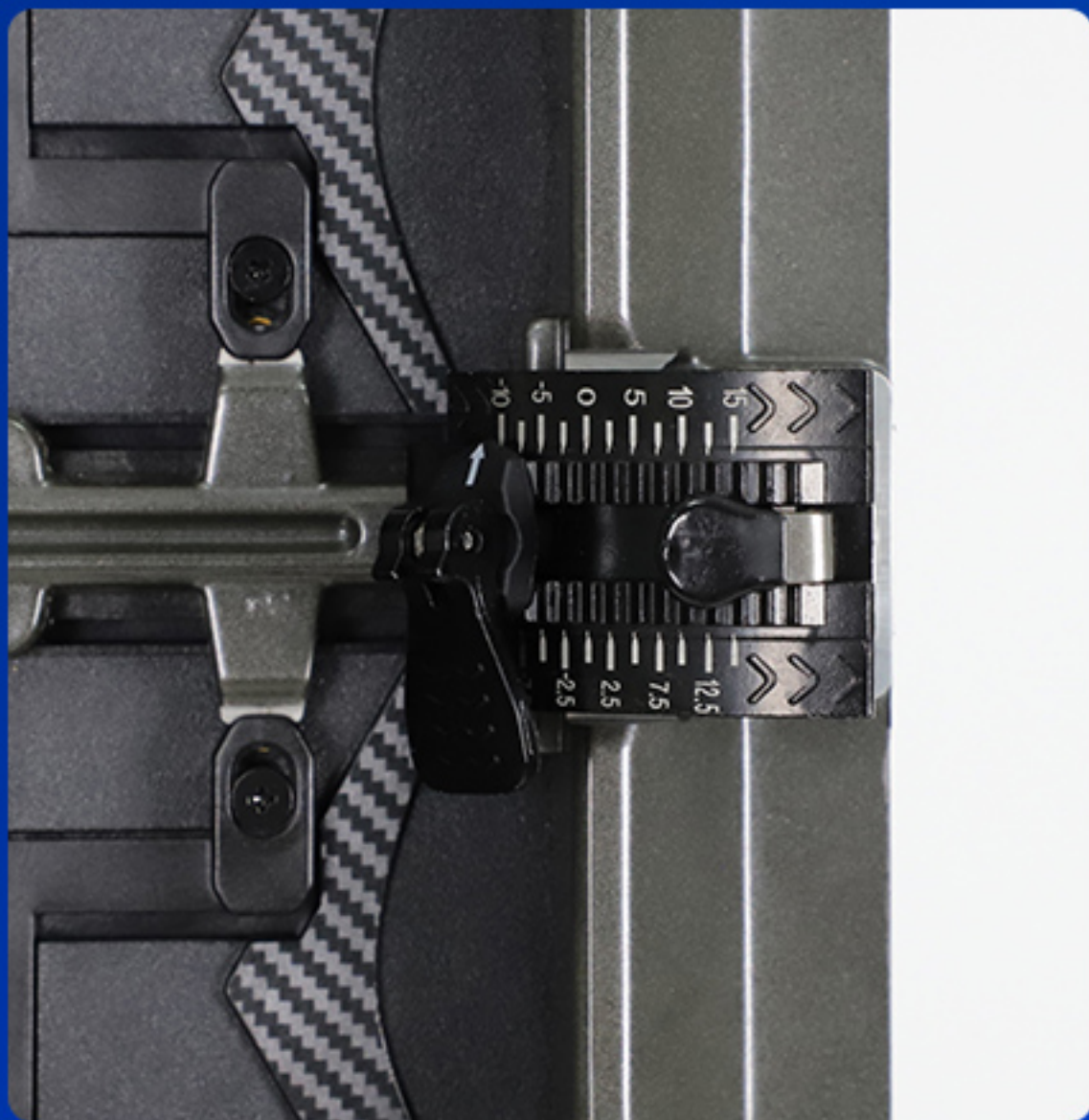

INDOOR & OUTDOOR 500X1000MM RENTAL LED DISPLAY



# 45° Beveled Cabinet (Optional)

Optional bevel cabinet,  
supports 90 degree  
installation

INDOOR & OUTDOOR 500X1000MM RENTAL LED DISPLAY

INDOOR & OUTDOOR 500X1000MM RENTAL LED DISPLAY

EA1000H6 SERIES

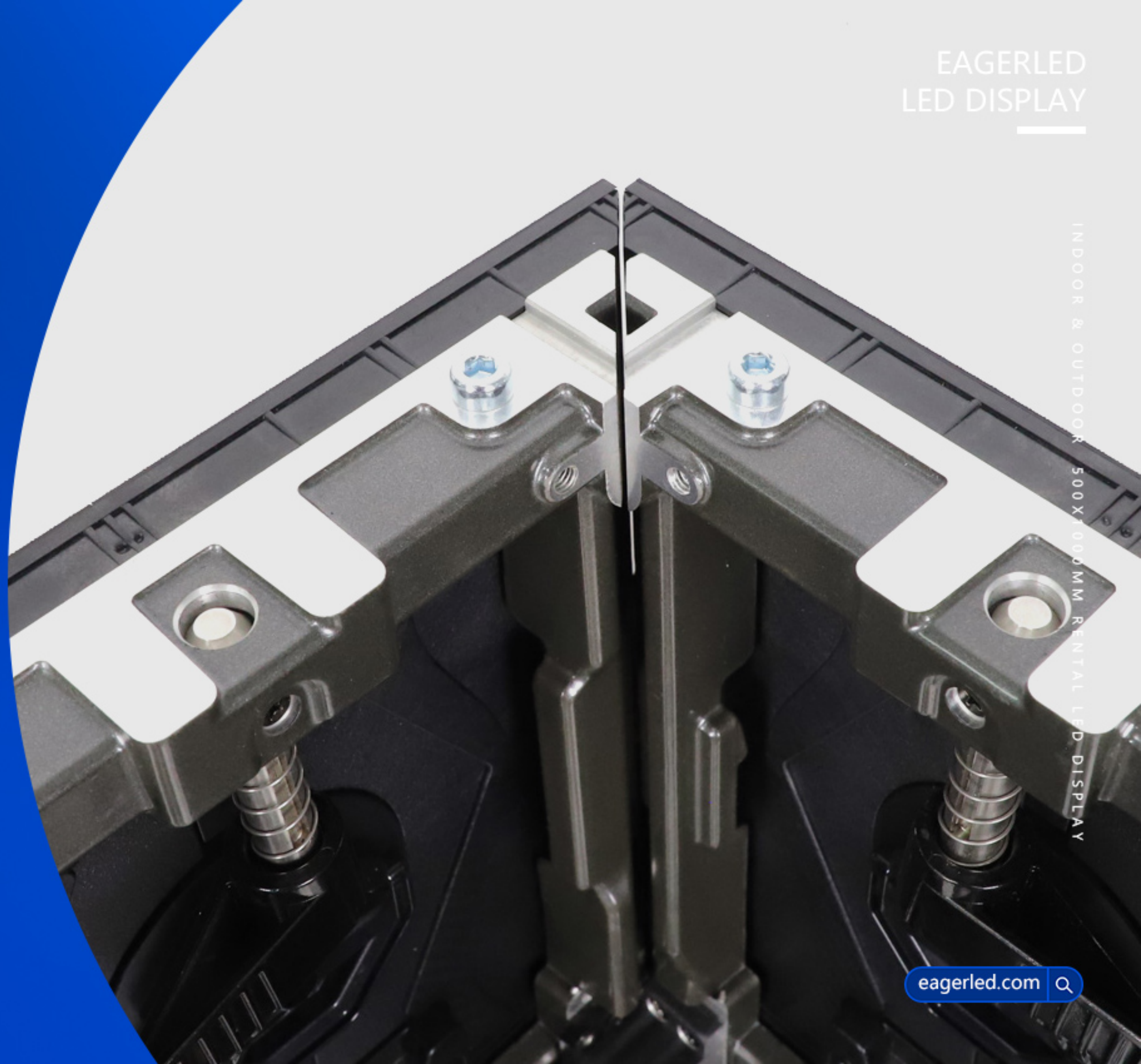



# Superb Display Effect

3840Hz high refresh rate  
High gray scale

Low refresh rate  
Low grayscale

VS

EagerLED EA1000H6

Competing Product



# Installation Method

INDOOR & OUTDOOR 500X1000MM RENTAL LED DISPLAY



Stacking installation



Hanging installation

INDOOR & OUTDOOR 500X1000MM RENTAL LED DISPLAY



# Multiple Applications

INDOOR & OUTDOOR 500X1000MM RENTAL LED DISPLAY



INDOOR & OUTDOOR 500X1000MM RENTAL LED DISPLAY



# Packing Method

(Refer to the packaging method)

Cabinet size(mm)	500*1000(L*H)
Packing Quantity	6pcs/carton
Package Size(mm)	1110*750*745(L*W*H)













# EagerLED Leading LED Display Manufacturer



Whatsapp

+86 152 2013 3050



Website

[eagerled.com](http://eagerled.com)



Youtube

[@EagerLED](https://www.youtube.com/@EagerLED)



Tiktok

[@eagerleddisplay](https://www.tiktok.com/@eagerleddisplay)